



UNHCR

United Nations High Commissioner for Refugees
Haut Commissariat des Nations Unies pour les réfugiés

ITB/2024/015

Questions & Answers

Q1: For the Material that will be used is it (PP, PE, HDPE,) or (PVC, PET, ABS) , Is it Soft or hard?

A1: Soft

Q2: The power Supply of the machines is 220v /50Hz 1ph or 380/50Hz/3 ph.?

A2: 3ph/ 380V / 50Hz

Q3: Is there drawings for the line ?

A3: No

Q4: Item 1 – Shredder : It is mentioned: “Size of shredded plastics 0.6-2.36 mm”. Please note that this range is used usually with road construction and it is not applicable for plastic recycling. Normally shredded plastic for recycling is approx. 30mm and crushed plastics is 12-14mm. Please confirm if it would be possible to offer based on our recommendations.

A4: Yes possible, please submit the datasheet for your machine, and we can review.

Q5: Item 2 : No. 2: Washing Line: It is mentioned: “All types of common municipal plastic waste in a variety of materials such HDPE, LLDPE, PP, ABS, HIPS, Nylon, PC, PET into a plastic profile”. Will these plastics be handled separately or together?

A5: Separately.

Q6: Item 3: Extruder: Is this extruder used for plastic profile extrusion?

A6: Yes exactly

Q7: Item 3 : Extruder: Can you provide us with the shape and dimension of the plastic profile? Since the extrusion mold is different due to different profile shape.

A7: 40x40 mm and 30x30mm either full or hollow profile.

Q8: Item 3 : Extruder: Please note that usually a single screw extruder is for PE PP plastic extrusion, while a twin-screw extruder is used to handle PET plastic. Therefore, please confirm whether it would be possible to offer twin-screw extruder.

A8: based on data sheet provided, You may quote the suitable option.

Q9: Item 4: Compactor: Please advise on the role of the compactor. Is it used for compacting plastic film soft material into small pellets?

A9: Iron Hydraulic Disposable Plastic Plate Machine to create 1x1m plate of 4mm thickness from plastic flakes." The compactor is used to compact the plastic into plates..

Q10: For the Material that will be used is it (PP, PE, HDPE,) or (PVC, PET, ABS) , Is it Soft or hard?

A10: Soft

Q11: The power Supply of the machines is 220v /50Hz 1ph or 380/50Hz/3 ph.?

A11: 3ph/ 380V / 50 Hz

Q12: Is there drawings for the line or do you have AutoCAD drawings to the Area that will be fixing the line ?

A12: No.

Q13: As pair your request we want to confirm that the lines requested is to recycle all plastics as I want to confirm to you we will be providing a line scale program for types of plastics used

A13: Question is not clear.

Q14: Do you have an image for the types of wastes that will be used as captured images ?

A14: materials are annexed below.

Q15: Can we arrange a site visit for the following location that the machines will be stored and placed. Working Area .

A15: Not at this stage



UNHCR

United Nations High Commissioner for Refugees
Haut Commissariat des Nations Unies pour les réfugiés

Q16: IF it's not possible to arrange a site visit can we have the contact info for the engineer of the following project?

A16: I do not think that we can say Yes to this question, we are happy to support in answering the questions through you as supply colleague.



End of Questions

Item Application Sample



General Information and Description

Reinforced plastic tarpaulin in bales or rolls of 4 x 50 meters was developed by an international research project and was designed for long outdoor use in all climates and to be used for simple temporary community shelter protection. Several other uses include, covering damaged structures, upgrading of tents and shelters, building of latrine's fencing, health centers, ground sheet or food mound protection.

Technical Specifications

Finished size for each plastic bale or roll: 4 X 50 meters ± 1%.

Material: made of woven high-density black polyethylene (HDPE) fibers, warp x weft, laminated on both sides with low density polyethylene (LDPE) coating.

Material weight: minimum 190 g/m² ±20 g/m².

Tensile strength: minimum 600N both directions of warp and weft (BS2576, 50 mm grab test, or equivalent).

Tear strength: minimum 100 N both directions (BS 4303 wing tear or equivalent) or under ISO 4674 (A2).

UV resistance: stabilized against ultraviolet rays and excess heat for long outdoor exposure. Around 5% loss on original tensile strength under ISO 1421 after 1500 hours UV under ASTM G53/94 (UVB 313 nm peak). The final tensile should not be below 570N.

Welding: only one (01) is allowed along the middle of the sheet, length wise. Minimum resistance is 80% of the original tarpaulin tensile strength in the weft (and not less than 480N) under ISO 1421 plus additional procedure.

Color: white sun reflective on both sides. Inner black fibers to ensure opacity.

Flame retardant under EN 13823 + A1 and CPAI84:

Pass EN 13823 + A1 with the minimum class D, s2, d2.

Pass CPAI84 sections 5 and 6 with maximum 10 s after flame average and maximum 30 s after flame per test piece.

Ageing under ISO 4892-2, type A, 360 hours.

Weight and Volume

Total weight per tarpaulin: 33.66 to 43.35 kg

Total weight per bale: 34.06 to 43.83 kg

Gross volume per piece / bale: approx. 0.0743m³

Bale dimensions: 56 x 78 x 17 cm

Packing in Bales

The 4 x 50 m tarpaulins are packed individually on 56 x 78 x 17 cm bales (for maximum loading capacity on Euro pallets), folded in the middle and tied. Wrapped in polyethylene, sealed with a polyester band.

Optional Packing in Rolls

In order to maximize loadability in pallets and containers, it is ideal is to pack the 4 x 50 m tarpaulins centre folded lengthwise and tightly rolled. The product is to be wrapped in polyethylene, and sealed with a polyester band.

Optimal Shipping / Container Information

380 bales per 20' DC (without pallets).

710 bales per 40' DC (without pallets).

710 bales per 40' HC (without pallets).

336 bales per 20' DC (with pallets).

696 bales per 40' DC (with pallets).

696 bales per 40' HC (with pallets).

CRI Pallet Details

Fumigated as per IPSM 15 standard. Dimensions (L x W x H): 115 cm (+1 / -3 cm tolerance) x 77 cm (+/- 1 cm tolerance) x 14.4 cm. Maximum height of the packed pallet: 115 cm. Pallets should be shrink-wrapped and strapped. The palletized goods must not exceed the length and width of the pallet. For further information please refer to the Optimal Shipping / Container Information section.

Manufacturer Marking

Every tarpaulin sheet 4 x 50 m should include a tag stitched at joint, with the manufacturer identification (letters not higher than 2.5 cm). The tag should include the manufacture's name, unique reference batch number and the date of manufacturing. No company logo should be included with the manufacturer's marking.

Expected Life Span

It is expected that Reinforced Plastic Tarpaulin in bales or rolls 4 x 50 m will maintain sheltering and waterproof capacities for one year under the strongest tropical conditions. It has a shelf life span of 6 years.

Reference Information

For additional information about the use of this product see:
<http://www.plastic-sheeting.org>
<http://www.sheltercentre.org/library>

Graphic Reference

A line with UNHCR logos must be printed on both sides of the plastic bale or roll, placed one meter from the bottom edge of the long side on the tarpaulin.

For UNHCR visibility logo printing purposes details, see the Reinforced Plastic Tarpaulin Graphic and the UNHCR Logo Application reference, where size of logo is 51,5 cm wide and 55 cm height. The distance (space) between each logo should be no longer than 60 cm or shorter than 40 cm.

Typeface (Font), Colour specifications for printing:

Font: Helvetica Bold. Colour specification: Pantone Blue 300 or quadrichrome (CMYK). C = 100%, M = 45%, Y = 0%, K = 0%.



4 x 50 m

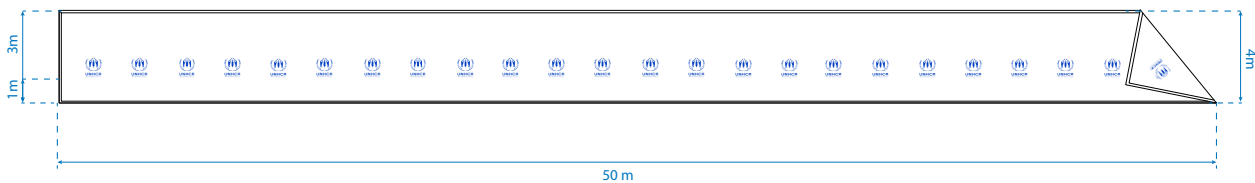

UNHCR Logo Application Reference

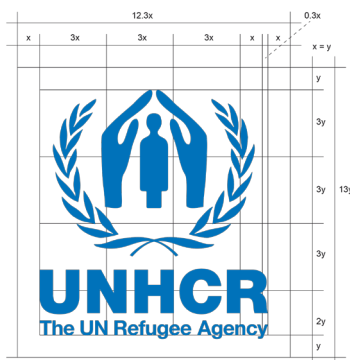

**UNHCR**United Nations High Commissioner for Refugees
Haut Commissariat des Nations Unies pour les réfugiés**REINFORCED PLASTIC TARPULIN WITH EYE-
LETS AND FIRE RETARDANT(SHEET 4X5 m)****UNHCR Item No 07197****Item Application Sample****General Information and Description**

Reinforced plastic tarpaulin in sheets of 4 x 5 meters was developed by an international research project and designed for long outdoor use in all climates. Plastic Tarpaulins are to be used in support to humanitarian operations, for temporary shelter and are recommended for individual (family) shelter protection.

Technical Specifications

Tarpaulin Size: the finished size of each sheet is 4 x 5 meters ±1%.

Effective area: 20.00 m².

Material: made of woven high-density black polyethylene (HDPE) fibers, warp x weft, laminated on both sides with low density polyethylene (LDPE) coating, with reinforced rims by heat sealing on all sides, (or 2 sides heat sealing and 2 sides double stitching), and a 5 millimeters diameter PE or PP rope on the edge, inside the hem. 1000 denier minimum.

Material net weight: minimum 190 g/m² ±20 g/m².

Tensile strength: minimum 600 N both directions of warp and weft (BS 2576, 50 mm grab test, or equivalent).

Tensile strength of the eyelets: minimum 700N inside the eyelets as per ISO 1421-1, pulling lengthwise with a hook of 8mm wire diameter. To test in 2 eyelets in each side.

Tear strength: minimum 100 N both directions (BS 4303 wing tear or equivalent) or under ISO 4674 (A2).

UV resistance: stabilized against ultraviolet rays and excess heat for long outdoor exposure. Maximum 5% loss on original tensile strength under ISO 1421 after 1500 hours UV under ASTM G53/94 (UVB 313 nm peak).

Welding: only one (01) is allowed along the middle of the sheet, length wise. Minimum resistance is 80% of the original tarpaulin tensile strength in the weft under ISO 1421 plus additional procedure.

Reinforcement eyelets: provided with aluminum eyelets or equivalent on four sheet sides of the single sheets at 100 cm ±5 cm centre to centre, providing very strong fixation points.

Color: white sun reflective on both sides. Inner black fibers to ensure opacity.

Fire Retardant: PASS - CPAI 84 section 6 as received, maximum average damage length: 190mm, max damage length of each specimen: 225mm, average after-flame time: 2s, max after-flame of each specimen: 4s.

PASS CPAI 84 section 6 after leaching, maximum average damage length: 190mm, max damage length of each specimen: 255mm, average after-flame time: 2s, max after-flame of each specimen: 4s.

PASS - CPAI 84 section 6 after 360 h QUV, maximum average damage length: 190mm, max damage length of each specimen: 255mm, average after-flame time 2s, max after-flame of each specimen: 4s.

Weight and Volume

Considering the weight of the welding and reinforcement eyelets.

Gross weight per piece: 3.55 kg to 4.65 kg

Gross weight per bale: 20 kg approx.

Gross volume per bale: approx. 0.0437 m³.

Bale Dimension: 56 x 39 x 20 cm

Packing

Plastic tarpaulin sheets are packed in bales. It is ideal to pack 5 pieces of product per bale, and to secure it with polyester straps. However different packing methods may be accepted in order to maximize loadability in pallets and containers.

Optimal Shipping / Container Information

3.300 pieces / sheets per 20'GP (without pallets).

6.500 pieces / sheets per 40'DC (without pallets).

6.500 pieces / sheets per 40' HC (without pallets).

2.800 pieces / sheets per 20' DC (with pallets).

6.000 pieces / sheets per 40' DC (with pallets).

6.000 pieces / sheets per 40' HC (with pallets).

Pallet Details

Dimensions (W x L x H): 780 x 1120 x 144 mm. Maximum height of the packed pallet: 115 cm. Pallets should be shrink-wrapped and strapped. The palletized goods must not exceed the length and width of the pallet.

Manufacturer Marking

Every tarpaulin sheet 4 x 5 m should include a tag stitched in hem, with the manufacturer identification (letters not higher than 2.5 cm). The tag should include the manufacturer's name, unique reference batch number and the date of manufacturing. No company logo should be included with the manufacturer's marking.

Expected Life Span

It is expected that Reinforced Plastic Tarpaulin will maintain sheltering and waterproof capacities for one year under the strongest weather conditions.

Reference Information

For additional information about the use of this product see:

<http://www.plastic-sheeting.org>
<http://www.sheltercentre.org/library>

Note: last updated, June 2014



Graphic Reference

PRINTING OF UNHCR LOGO: A line with UNHCR logos must be printed on both sides of the plastic bale or roll, placed one meter from the bottom edge of the long side on the tarpaulin. For UNHCR visibility logo printing purposes details, see the Reinforced Plastic Tarpaulin Graphic and the UNHCR Logo Application reference available on the next page, where size of logo is 45 cm wide and 55 cm height. Alternatively, the size of the logo could be 50 cm wide x 60 cm height. The distance (space) between each logo should be no longer than 60 cm or shorter than 40 cm.

Typeface (Font), Colour specifications for printing:

Font: Helvetica Bold. Colour specification: Pantone Blue 300 or quadrichrome (CMYK). C = 100%, M = 45%, Y = 0%, K = 0%.

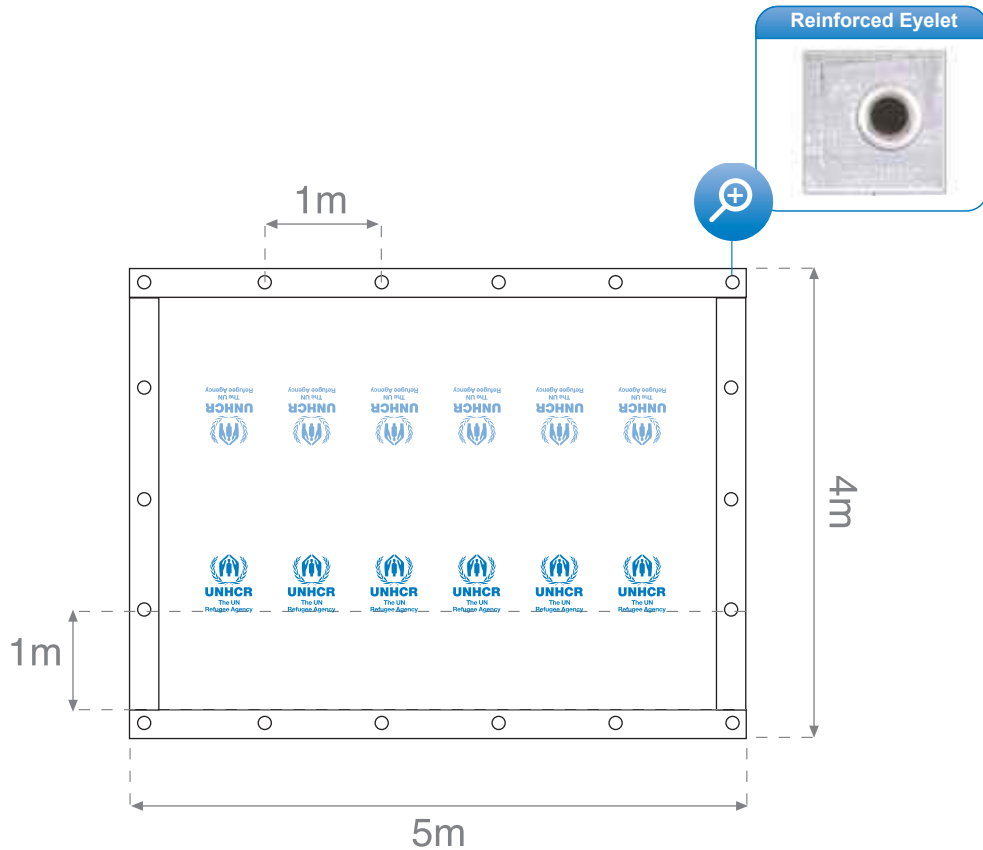

UNHCR Logo Application Reference

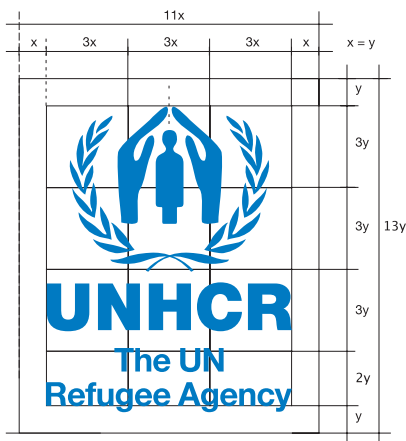

Logo Application Reference

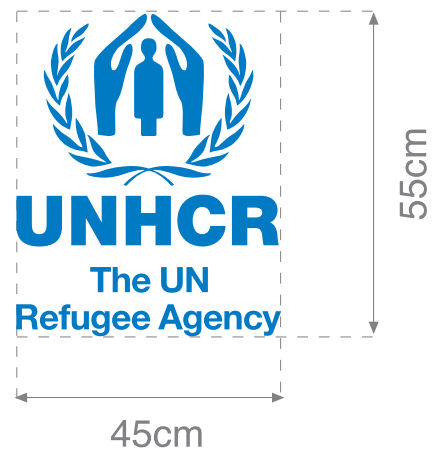

Logo Application Size



UNHCR

United Nations High Commissioner for Refugees
Haut Commissariat des Nations Unies pour les réfugiés

REINFORCED PLASTIC TARPULIN WITH EYE-LETS AND FIRE RETARDANT(SHEET 4X5 m)

UNHCR Item No 07197

Item Application Sample



General Information and Description

Reinforced plastic tarpaulin in sheets of 4 x 5 meters was developed by an international research project and designed for long outdoor use in all climates. Plastic Tarpaulins are to be used in support to humanitarian operations, for temporary shelter and are recommended for individual (family) shelter protection.

Technical Specifications

Tarpaulin Size: the finished size of each sheet is 4 x 5 meters ±1%.

Effective area: 20.00 m².

Material: made of woven high-density black polyethylene (HDPE) fibers, warp x weft, laminated on both sides with low density polyethylene (LDPE) coating, with reinforced rims by heat sealing on all sides, (or 2 sides heat sealing and 2 sides double stitching), and a 5 millimeters diameter PE or PP rope on the edge, inside the hem. 1000 denier minimum.

Material net weight: minimum 190 g/m² ±20 g/m².

Tensile strength: minimum 600 N both directions of warp and weft (BS 2576, 50 mm grab test, or equivalent).

Tensile strength of the eyelets: minimum 700N inside the eyelets as per ISO 1421-1, pulling lengthwise with a hook of 8mm wire diameter. To test in 2 eyelets in each side.

Tear strength: minimum 100 N both directions (BS 4303 wing tear or equivalent) or under ISO 4674 (A2).

UV resistance: stabilized against ultraviolet rays and excess heat for long outdoor exposure. Maximum 5% loss on original tensile strength under ISO 1421 after 1500 hours UV under ASTM G53/94 (UVB 313 nm peak).

Welding: only one (01) is allowed along the middle of the sheet, length wise. Minimum resistance is 80% of the original tarpaulin tensile strength in the weft under ISO 1421 plus additional procedure.

Reinforcement eyelets: provided with aluminum eyelets or equivalent on four sheet sides of the single sheets at 100 cm ±5 cm centre to centre, providing very strong fixation points.

Color: white sun reflective on both sides. Inner black fibers to ensure opacity.

Fire Retardant: PASS - CPAI 84 section 6 as received, maximum average damage length: 190mm, max damage length of each specimen: 225mm, average after-flame time: 2s, max after-flame of each specimen: 4s.

PASS CPAI 84 section 6 after leaching, maximum average damage length: 190mm, max damage length of each specimen: 255mm, average after-flame time: 2s, max after-flame of each specimen: 4s.

PASS - CPAI 84 section 6 after 360 h QUV, maximum average damage length: 190mm, max damage length of each specimen: 255mm, average after-flame time 2s, max after-flame of each specimen: 4s.

Weight and Volume

Considering the weight of the welding and reinforcement eyelets.

Gross weight per piece: 3.55 kg to 4.65 kg

Gross weight per bale: 20 kg approx.

Gross volume per bale: approx. 0.0437 m³.

Bale Dimension: 56 x 39 x 20 cm

Packing

Plastic tarpaulin sheets are packed in bales. It is ideal to pack 5 pieces of product per bale, and to secure it with polyester straps. However different packing methods may be accepted in order to maximize loadability in pallets and containers.

Optimal Shipping / Container Information

3.300 pieces / sheets per 20'GP (without pallets).

6.500 pieces / sheets per 40'DC (without pallets).

6.500 pieces / sheets per 40' HC (without pallets).

2.800 pieces / sheets per 20' DC (with pallets).

6.000 pieces / sheets per 40' DC (with pallets).

6.000 pieces / sheets per 40' HC (with pallets).

Pallet Details

Dimensions (W x L x H): 780 x 1120 x 144 mm. Maximum height of the packed pallet: 115 cm. Pallets should be shrink-wrapped and strapped. The palletized goods must not exceed the length and width of the pallet.

Manufacturer Marking

Every tarpaulin sheet 4 x 5 m should include a tag stitched in hem, with the manufacturer identification (letters not higher than 2.5 cm). The tag should include the manufacturer's name, unique reference batch number and the date of manufacturing. No company logo should be included with the manufacturer's marking.

Expected Life Span

It is expected that Reinforced Plastic Tarpaulin will maintain sheltering and waterproof capacities for one year under the strongest weather conditions.

Reference Information

For additional information about the use of this product see:

<http://www.plastic-sheeting.org>
<http://www.sheltercentre.org/library>

Note: last updated, June 2014



Graphic Reference

PRINTING OF UNHCR LOGO: A line with UNHCR logos must be printed on both sides of the plastic bale or roll, placed one meter from the bottom edge of the long side on the tarpaulin. For UNHCR visibility logo printing purposes details, see the Reinforced Plastic Tarpaulin Graphic and the UNHCR Logo Application reference available on the next page, where size of logo is 45 cm wide and 55 cm height. Alternatively, the size of the logo could be 50 cm wide x 60 cm height. The distance (space) between each logo should be no longer than 60 cm or shorter than 40 cm.

Typeface (Font), Colour specifications for printing:

Font: Helvetica Bold. Colour specification: Pantone Blue 300 or quadrichrome (CMYK). C = 100%, M = 45%, Y = 0%, K = 0%.

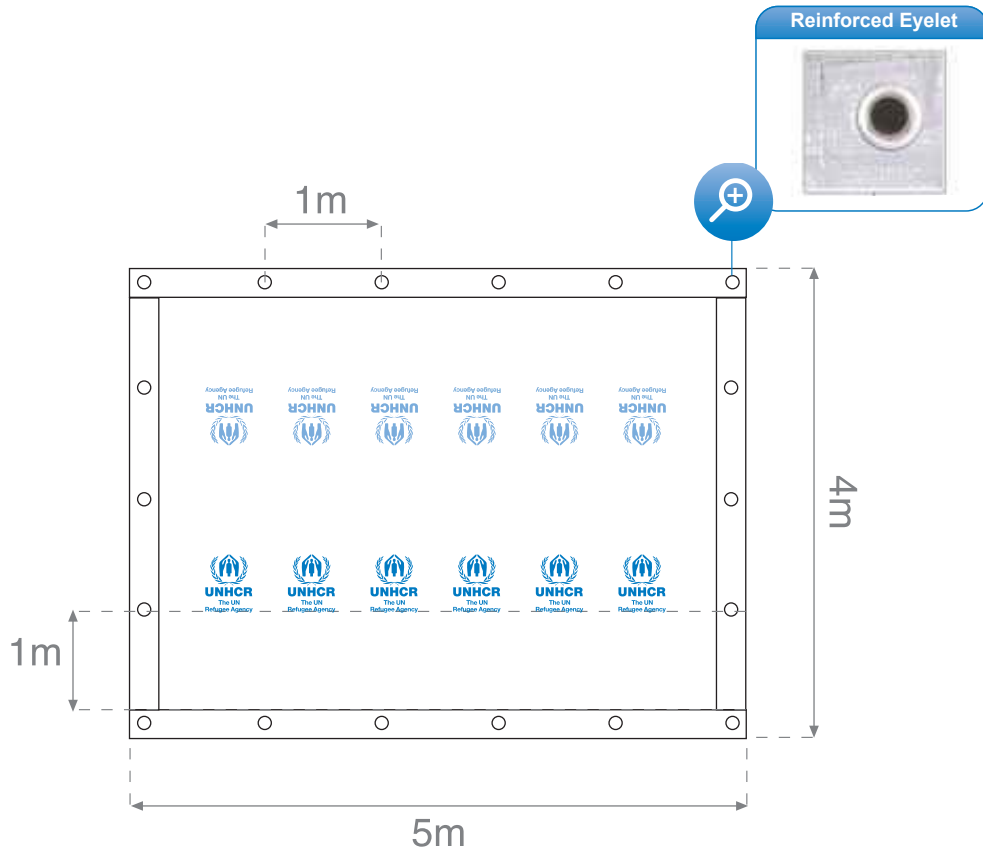

UNHCR Logo Application Reference

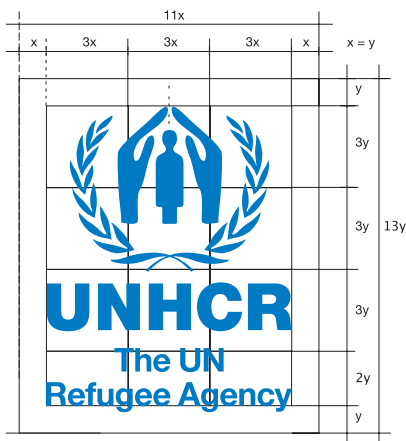

Logo Application Reference

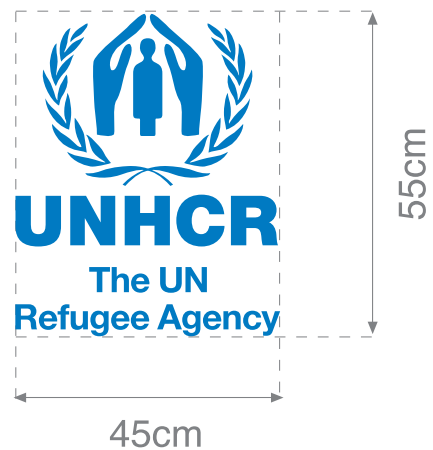

Logo Application Size