

## **Invitation to bid**

## **Request for quotation**

**Title:** Installation of PV solar system in Tripoli

**Reference:** LRC-0102023

**Submitted on:** 20-10-2023

**Description:** Installation of PV solar system for 12 shops in Tripoli

## Table of Contents

<b>Section 1: About LebRelief - LRC.....</b>	<b>4</b>
<b>Section 2: Bid data sheet .....</b>	<b>4</b>
Background Data:.....	4
Reference:.....	4
Location of work: .....	4
Scope of work: .....	4
The deadline for submission: .....	4
<b>Section 3: Further information .....</b>	<b>5</b>
1. Scope of price offer:.....	5
2. Finalizing of Price Offer Submission:.....	5
3. Corrupt Practices: .....	5
4. Currencies of Price Offer and Payment: .....	5
5. Format and Signing of Price Offer:.....	5
6. Withdrawal and Replacement of Bids: .....	5
7. Confidentiality:.....	5
8. Clarification of Bids: .....	5
<b>Section 4: Qualified bidder .....</b>	<b>5</b>
Evaluation of Bids: .....	6
Award Procedure: .....	7
Signing of Contract:.....	7
<b>Section 5: Obligations and Requests .....</b>	<b>7</b>
<b>Section 6: Condition of Contract .....</b>	<b>8</b>
1. Penalties:.....	8
2. Legal status: .....	8
3. Ethical standards:.....	8
4. Conflict of interest: .....	8
5. Obligations: .....	8
6. Contract management:.....	8
7. Acceptance and acknowledgment:.....	8
8. Inspection:.....	8
9. Force majeure: .....	8
10. Default:.....	9
11. Rejection: .....	9
12. Bankruptcy: .....	9
13. Amendments:.....	9
14. Assignments: .....	9

15.	Disputes – Arbitration:.....	9
16.	Use of name, emblem or official seal: .....	9
17.	Notice:.....	9
18.	Liquidated damages:.....	9
19.	Anti-personnel weapons producers:.....	9
20.	Child labor: .....	9
21.	Prior negotiations superseded by contract: .....	10
22.	Intellectual property infringement: .....	10
23.	Title rights: .....	10
24.	Insurance:.....	10
25.	Payment schedule:.....	10
26.	Transparency:.....	10
27.	Acceptance:.....	10
<b>Section 7: Agreement between: .....</b>		<b>10</b>

## Section 1: About LebRelief - LRC

Lebanese Relief Council (LebRelief - LRC) is a non-political nongovernmental organization (NGO) located in Lebanon. LebRelief has currently offered essential services to refugees residing in informal settlements, finished and unfinished buildings, and in collective shelters and for hosting community in collaboration with municipalities and local and international NGOs. The motivated LebRelief team approaches each engagement with utmost dedication and commitment for the cause it serves. As a result, LebRelief is unique in its devotion and loyalty for human rights principles regardless from any other factor.

Our vision is to provide humanitarian aid and economic development to the impoverished communities within Lebanon as well as the refugees in the fastest and most efficient way possible, in order to release the tension between the two parties and foresee a sustainable society.

The mission of LebRelief is to secure protection for most vulnerable individuals by responding to their needs through services that revolve around economic development, the providing of services, shelter, WASH, Health Care, Social Cohesion and Information and Legal Assistance. With the collaboration of local and international partners, we will be able to reach a consensus within the community that is respected and sustainable for all.

## Section 2: Bid data sheet

Association LRC wishes to invite you to the invitation to bid for **the installation of PV solar system in Tripoli.**

**Background Data:** The proposed bid is to be willing to install the needed systems.

**Reference:** The reference number of this bid is **LRC-0102023** as stated by LebRelief.

**Location of work:** Tripoli area: Zahriye and Beb El Ramel

**Scope of work:** Installation of PV solar system in Tripoli.

The bidders are hereby invited to provide a price offer on the following work components:

- Fill detailed Price offer describing the needed material for the completion of the assigned work.
- Complete the delivery of materials within the required safety measures mentioned.

**The deadline for submission:** The deadline of submission of this bid will be on the third of November 2023 at 17:00 pm. Bids shall be opened directly after the deadline of submission. All bids must be filled, signed, stamped and submitted in sealed envelopes to LebRelief offices. For any further clarification, kindly contact us by email on [tender@leb-relief.org](mailto:tender@leb-relief.org), or by phone on 81 336 492.

### Section 3: Further information

1. **Scope of price offer:** The awarded bidder will deliver needed goods, works, or services within the needed requirement of LebRelief, as per the price in submitted quotation form.

2. **Finalizing of Price Offer Submission:**

The Bidder is expected to examine all instructions, forms, terms, and specifications in the Bidding Document. Failure to furnish all information or documentation required by the Bidding Document may result in the rejection of the bid.

3. **Corrupt Practices:** LebRelief requires Employees, Bidders and Vendors, to work under the highest standards of ethics during the preparation, delivering of supply component, and execution of contracts. Where the following should be avoided:

1. Corrupt practice includes the offering or receiving of anything of value to influence the action of a public official in the supplying process or in contract execution;
2. Fraudulent practice includes a falsification of facts in order to influence a procurement process or the execution of a contract;

In the case where the bidder, employee, or vender fails to avoid fraud and/or corruption, LebRelief will:

- Reject any bids related to that person
- Remove these bidding contractors from our prequalified list
- Contact and report District Officials
- Terminate works

4. **Currencies of Price Offer and Payment:** The bidder shall quote all prices in USD currency. Similarly, all payments will be made in USD unless requested by the bidder and approved upon by LebRelief to be in another currency.

5. **Format and Signing of Price Offer:** The Bidder shall prepare one set of Price offer document per contract that he/she wishes to bid for. The bidder should hold a copy of the documents with himself, for reference purposes.

6. **Withdrawal and Replacement of Bids:** A Bidder may withdraw or replace his/her price offer after it has been submitted at any time before the deadline.

7. **Confidentiality:**

- Examination, evaluation, comparison, and post-qualification of bids, shall not be disclosed to bidders or any other person.
- Any effort by a Bidder to influence Association LRC in the examination, evaluation, comparison, and post - qualification of the bids or contract award decisions may result in the rejection of his/her price offer.

8. **Clarification of Bids:** Association LRC may, at its discretion, ask any Bidder for a clarification of his/her Price Offer. Association LRC's request for clarification and the response shall be either in writing (signed) submitted at LebRelief - LRC's office or via email at [tender@leb-relief.org](mailto:tender@leb-relief.org).

### Section 4: Qualified bidder

A Bidder is encouraged to submit papers proving the following in order to participate in LebRelief

selection:

- Bidder must send his official registration documents
- Bidder must sign and stamp the invitation to bid (Attached)
- Bidder must sign and stamp the sworn declaration (Attached)
- Bidder must fill, sign and stamp the third party beneficiary information (Attached)
- Bidder must fill, sign and stamp the price offer (Attached)

A Bidder whose circumstances in relation to the above mentioned statuses changes during the supplying processor during the execution of a contract shall immediately inform LebRelief.

A Bidder, and all parties constituting the Bidder including sub-contractors, shall not have a conflict of interest. All Bidders found to have a conflict of interest shall be disqualified. A Bidder may be considered to have a conflict of interest with one or more parties in this bidding process, if they have a relationship with each other, directly or through common third parties, that puts them in a position to have access to information about or influence on the bid of another Bidder, or influence the decisions of the Association LRC regarding this bidding process.

The Contractor shall abide to design in full compliance with all relevant requirements and specifications. Relevant tests required by the NGO technical teams must be submitted for their approval. If the client decides to cancel any items listed in the Bills of Quantities, the Contractor shall not claim any compensation related to the works not executed.

**A clarification online session will be held online on Tuesday 24<sup>th</sup> of October 11:00 AM to explain the needed documents. Link of the online session:**

**<https://us04web.zoom.us/j/79682477062?pwd=LX4WXNKbqCm60rLGBYLAh04g4hhVdV.1>**

**Evaluation of Bids:**

1. Association LRC shall examine the legal documentation and other information submitted by Bidders to verify eligibility, and then will review and score Bids according to the following criteria:
  - Experience: 15 points
  - Price: 50 points
  - Quality: 30 points
  - Delivery time frame: 5 points
2. Bidder selection criteria:

#	Criteria	Sub-Criteria	Maximum score	0 (if not provided)	1
1	Experience	Similar past contracts	3	The bidder has provided no past contract similar to the contract to award	The bidder has provided at least one past contract similar to the contract to award
		Amount of past contract	3	<b>No similar past contract provided</b> has an amount is equal or above the contract amount to be awarded	The amount of a similar past contract provided <b>is equal or above</b> the contract amount to be awarded
		Positive experience with LebRelief	3	The bidder proved <b>weaknesses</b> in executing past contracts awarded by LebRelief as per supplier database	The bidder has a <b>positive</b> record as per LebRelief supplier database
		Company portfolio or CV or list of projects	3	The bidder has been working in this business for <b>less</b> than 5 years	The bidder has been working in this business for <b>5 years or more</b> than 5 years
		Positive reference check (recommendation letters or emails)	3	The bidder has a <b>negative</b> record as per contacted NGOs / private companies	The bidder has a <b>positive</b> record as per contacted NGOs / private companies

3. Bids award criteria (Technical assessment):

#	Criteria	Sub-Criteria	Maximum score	0 (If info not provided)	1	2	3	4	5
2	Price	N/A	50	The price is scored proportionally from the lowest bid price					
3	Quality	Data sheets submitted (material submittals shall include ISO certification and IEC certification) (material to be submitted is attached to the price offer)	30	3 of 18 items or below for material data sheet approved	6 of 18 items for material data sheet approved	9 of 18 items for material data sheet approved	12 of 18 items for material data sheet approved	15 of 18 items for material data sheet approved	18 of 18 items for material data sheet approved
4	Availability	Delivery timeframe	5	For 5 weeks or more exceeding delivery time	For 4 weeks exceeding delivery time	For 3 weeks exceeding delivery time	For 2 weeks exceeding delivery time	For 1 week exceeding delivery time	Equal or lower the requested delivery time

4. All materials used are to be of the best new available and subject to the Employer/Engineer approval, and of durable nature, guaranteed, not liable to any base exchange and manufactured according to applicable Standards.
5. In case of more than one contractor being scored the same in the evaluation with the same highest prequalification, re-pricing will take place between the equivalently scored vendors allowing the reconsideration of prices. If the scoring remains equivalent, the winning bidder will be identified via a draw in the presence of the bid evaluation committee and the concerned bidders.
6. Association LRC reserves the right to reject all bids, and re-tender if no satisfactory bids have been submitted

**Award Procedure:**

- The Association LRC shall award the Contract in writing.
- Any contractor who has not been awarded a contract will be notified either by email or by any other suitable way for both parties.

**Signing of Contract:** Upon receipt of the Letter of Acceptance, Association LRC shall call the successful Bidder to sign the Contract.

**Section 5: Obligations and Requests**

- The bidder shall abide to the instruction of LebRelief relevant teams.
- LebRelief has the right to ask for the substitution of the focal point of contact in case the NGO found that the focal point lacks experience and knowledge related to the project or for any other reasons evaluated by LebRelief.
- The bidder and/or the nominated focal point shall coordinate with LebRelief and concerned authorities in all cases specifically cases related to due dates and handing over.
- The bidder should take at his responsibility the application for any needed permit(s) from government department(s) and is deemed to acquire from concerned authorities all needed permits related to the targeted geographical area of implementation.
- The contractor is committed to all expenses that may arise from any modification and repairs resulted from the negligence and interruption of already existing infrastructures.

- The bidder shall take all needed safety measures in the implementation site including but not limited to safety of participants, safety of contractors labors and third party assets.
- Site Visit will be conducted on Wednesday the 25th of October at 10:00 am, Moussa Cafe-Beb Al Ramel at the below location: <https://maps.app.goo.gl/eBJ792VvMX2xbmFa6>
- The employer must stick to the materials submitted in the tender document. In case the material to be used is submitted in the tender documents, the bidder shall submit material for approval of the engineer before installation.

## Section 6: Condition of Contract

1. **Penalties:** Penalty for late delivery applies to each day (24 hour period), or part of a day after the dates and times given in the Delivery Schedule. Penalty comprises 2% of the total value of the order per day.
2. **Legal status:** The Vendors shall not be considered in any respect as being the employees of LebRelief. The Vendor shall be fully responsible for all work and services performed by its employees, and for all acts and omissions of such employees.
3. **Ethical standards:** All suppliers doing business with LebRelief - LRC should maintain high standards on ethical issues, respect and apply basic human and social rights, ensure non-exploitation of child labor, and give fair working conditions to their staff. LebRelief - LRC will not do business with producers of weapons, alcohol, tobacco or pornography.
4. **Conflict of interest:** Vendors must notify LebRelief - LRC if there is potential conflict of interest with any LebRelief - LRC staff prior to signing of this Contract. Any supplier failing to do so and later found to have a conflict of interest will be struck from the LebRelief - LRC vendor database.
5. **Obligations:** The Vendor shall neither seek nor accept instructions from any authority external to LebRelief - LRC.
6. **Contract management:** Any issues arising during this contract must be communicated either in writing between these two contacts or any other method suitable by both parties. Any adjustments to the Contract must also be noted in writing, with signatories from representatives of both parties.
7. **Acceptance and acknowledgment:** No Contract shall become effective and no Contract shall exist until LebRelief - LRC has received from the Vendor written acceptance of the conditions which govern this Contract by signature at the end of this Contract. Initiation of performance under this order by the vendor shall also constitute acceptance of the order by the vendor, including all terms and conditions herein contained or otherwise incorporated by reference. Each party of the Contract will hold a signed copy for reference.
8. **Inspection:** The representatives of LebRelief - LRC shall have the right to inspect the goods under this Contract at Vendor's stores, during manufacture, in the ports or places of shipment, and the Vendor shall provide all facilitate for such inspection. Inspection is at buyer's cost. If, however, an inspection must be repeated due to the vendor's default, or for the vendor's convenience, the cost of the second and any subsequent inspections for the same purchase order (or lot, if part inspection) will be charged to the vendor by the inspection company.
9. **Force majeure:** Force Majeure includes: natural disasters, local laws or regulations, industrial disturbances, acts of violence, civil disturbances, explosions and/or any other similar cause of equivalent force not caused by, nor within the control of, either party or which neither party is able to overcome. As soon as possible after the occurrence of a Force Majeure type situation; and within but not more than fifteen (15) days, the Vendor shall give notice and full particulars in writing to LebRelief - LRC of such Force Majeure. Otherwise, LebRelief - LRC shall then have the



right to cancel the Contract by giving, in writing, seven (7) days' notice of termination to the Vendor.

- 10. Default:** In case of default by the Vendor, including, but not limited to, failure or refusal to make deliveries within the limit specified, LebRelief - LRC may procure the goods or services from other sources, and hold the Vendor responsible for any excess cost occasioned thereby. Furthermore, LebRelief - LRC may, by written notice, terminate the right of the Vendor to proceed with deliveries or such part or parts thereof as to which there has been default.
- 11. Rejection:** In the case of goods or services purchased based on specifications or scope of works, LebRelief - LRC shall have the right to reject the goods or services or any part thereof if they do not conform to specifications or the scope of works.
- 12. Bankruptcy:** Should the Vendor be adjudged bankrupt, or should the Vendor make a general assignment for the benefit of its creditors, or should a receiver be appointed on account of the Vendor's insolvency, LebRelief - LRC may under the terms of this Contract, terminate this Contract forthwith by giving the Vendor written notice of such termination.
- 13. Amendments:** No change in or modification of this Contract shall be made except by prior agreement between the Project Manager of LebRelief - LRC and the Vendor. Amendments to this agreement shall be made in writing and signed by both parties.
- 14. Assignments:** The Vendor shall not assign, transfer, pledge or make other disposition of this Contract except with the prior written consent of LebRelief - LRC.
- 15. Disputes – Arbitration:** Any claim or controversy arising out of or relating to this or any contract resulting here-from, or to the breach, termination or invalidity thereof, shall be, unless settled amicably through negotiation, submitted to arbitration in accordance with LRC to specify.
- 16. Use of name, emblem or official seal:** Unless authorised in writing by LebRelief - LRC, the Vendor shall not advertise or otherwise make public the fact that he is a Vendor to LebRelief - LRC or use the name, emblem or official seal of LebRelief - LRC or any form of the name of Association LRC or LebRelief - LRC for advertising purposes or for any other purposes.
- 17. Notice:** Service of any notice shall be deemed to be good if sent by registered mail, fax or by cable to the addresses of both parties, set out in the heading of this Contract.
- 18. Liquidated damages:** Late delivery, or dispatch outside the agreed shipping schedule, shall be subject, without notice, to an assessment of liquidated damages equivalent to 0.1 percent of the Contract value per day. The assessment will not exceed 10 percent of the contract value. LebRelief - LRC has the right to deduct this amount from the Vendor's outstanding invoices, if any. This remedy is without prejudice to any others that may be available to LebRelief - LRC, including cancellation, for the Vendor's non-performance, breach or violation of any term or condition of the Contract. Acceptance of goods or services delivered late shall not be deemed a waiver of LebRelief - LRC's rights to hold the Vendor liable for any loss and/or damage resulted there-from, nor shall it act as a modification of the vendor's obligation to make future deliveries in accordance with the delivery schedule.
- 19. Anti-personnel weapons producers:** The Vendor guarantees that it is not engaged in the sale or manufacture, either directly or indirectly, of anti-personnel weapons. Any breach of this representation and warranty shall entitle LebRelief - LRC to terminate this Contract immediately upon notice to the Vendor, at no cost to LebRelief - LRC.
- 20. Child labor:** The Vendor represents and warrants that neither it, nor any of its vendors is engaged in any practice inconsistent with the rights set forth in the Convention on the Rights of the Child, including Article 32 thereof, which, inter alia, required that a child shall be protected from performing any work that is likely to be hazardous or to interfere with the child's education, or to

be harmful to the child's health and physical, mental, spiritual, moral or social development. Any breach of this representation and warranty shall entitle LebRelief - LRC to terminate this Contract immediately upon notice to the Vendor, at no cost to LebRelief - LRC.

- 21. Prior negotiations superseded by contract:** This Contract supersedes all communications, representations, arrangements, negotiations, requests for proposals and proposals related to the subject matter of this Contract.
- 22. Intellectual property infringement:** The Vendor warrants that the use or supply by LebRelief - LRC of the services or goods sold under this Contract does not infringe on any patent, design, trade-name or trade-mark. In addition, the Vendor shall, pursuant to this warranty, indemnify, defend and hold LebRelief - LRC and their donors harmless from any actions or claims brought against LebRelief - LRC or their donors pertaining to the alleged infringement of a patent, design, trade-name or trade-mark arising in connection with the goods sold under this Contract.
- 23. Title rights:** LebRelief - LRC shall be entitled to all property rights including but not limited to patents, copyrights and trademarks, with regard to material which bears a direct relation to, or is made in consequence of, the services provided to the organization by the Vendor. At the request of LebRelief - LRC, the Vendor shall take all necessary steps, execute all necessary documents and generally assist in securing such property rights transferring them to the organization in compliance with the requirements of the applicable law. Title to any equipment and supplies which may be furnished by LebRelief - LRC and any such equipment shall be returned to LebRelief - LRC at the conclusion of this Contract or when no longer needed by the Vendor. Such equipment, when returned to LebRelief - LRC, shall be in the same condition as when delivered to the Vendor, subject to normal wear and tear.
- 24. Insurance:** The vendor shall provide and thereafter maintain for the duration of this Purchase Order and any extension thereof all appropriate workmen's compensation insurance or its equivalent with respect to its employees to cover claims for personal injury and death in connection with a Purchase Order. The vendor shall, upon request, furnish proof to the satisfaction of LebRelief - LRC, of such liability insurance. The vendor shall further provide such health and medical insurance for its agents and employees, as the vendor may consider advisable. Contractor must insure his site against any incident that might occur to pedestrians and vehicles and against any third party claim with regard to his work on site. Insurance must cover the whole period of works on site.
- 25. Payment schedule:** The invoice will be paid by LebRelief - LRC upon an agreed schedule by both parties. Payment will be made either via Bank transfer or bank letter.
- 26. Transparency:** LebRelief - LRC undertakes to conduct transparent transactions in all operations. The parties agree that any payments related to this transaction are open and transparent.
- 27. Acceptance:** Please confirm your acceptance of this order by signing below, and ensure that all future correspondence includes the contract reference number.

### Section 7: Agreement between:

#### LebRelief Representative

Name:

Position:

Date:

Signature:

#### Bidder Representative

Name:

Position:

Date:

Signature:

# Beneficiary Profile

## Company Information

Your full name(represent)

Company name

Company's activity

*example : consulting company*

Address

City

Country

VAT number(\*)

Company Registration Date

Telephone (Area code + telephone number)

Email & Website

## Banking Information (Only if no IBAN)

Bank's name

Bank branch address

*(\*)Full Address*

City and Country

Bank Account Holder

*(The name is on a bank account)*

IBAN (International bank account number)

Bic/Swift (\*)

*(\*)Mandatory for all banks*

Deviser du compte (Account currency)

Monnaie Locale

Euros

Dollars

Local Currency

Stamp and signature of the bank (both obligatory)

Date

Full name - Signature

Please enclose your bank account identification form. Some countries or banks do not issue IBAN, this form should be signed and stamped by your bank.

Please ensure that all information has been entered on this form, otherwise the payments can be executed

In case of a change of account, please fill out this form with the new information.



Project Title: Supporting Lebanese CSOs to play a fundamental role in crisis management and providing sustainable support to vulnerable host communities and Syrian refugees

### PRICE OFFER

PR no(s): رقم طلب الشراء	Date RFQ sent out: تاريخ ارسال طلب عروض الأسعار	20-10-2023
	Date quotation due back: تاريخ استحقاق ارجاع عرض السعر	03-11-2023
	Proc. person responsible: مسؤول المشتريات	Ahmad Ismail

SUPPLIER NAME: معلومات المزود	RETURN QUOTATION TO: LRC إرجاع المناقصة إلى جمعية آل آر سي
Contact name الاسم	Contact name الاسم : Ahmad Ismail
E-mail/ البريد	E-mail/ البريد tender@leb-relief.org
Phone/ هاتف	Phone / هاتف
Fax/ فاكس	Fax / فاكس
Mobile/ موبايل	Mobile/ موبايل + 961 81 336 492
Address/ العنوان	Address/ العنوان Tripoli

Expected starting date: تاريخ بدأ الأعمال	15-11-2023
Expected delivery timeframe: تاريخ نهاية الأعمال	31-01-2024
Delivery address: عنوان الاستلام	Tripoli area: Zahriye and Beb El Ramel
Payment terms: شروط الدفع	USD Bank transfer or USD Bank letter

Line item no. رقم المادة	Description of Goods / Services وصف المواد / الخدمات المطلوبة (add attachment for technical specification if very detailed) (يضاف ملحقات في حال وجود تفاصيل تقنية)	Unit / Form الوحدة	Quantity required الكمية المطلوبة	For supplier to fill in: يتم تعبئتها من قبل المزود			
				Currency العملة	Unit Price سعر الوحدة	Total Price السعر الكامل	Comments
1	Supply and install the Solar panel   40V   545 watt   GRADE A Monocrystalline half cut per, Rated 1500Vdc, Voc 49.65V, Isc 13.58Amp, Imp 12.97Amp, Vmp 41.65V, Efficiency 21.1%, Dimension:2279 X 1134 X 35mm, with all required MC4 Connectors, connected to <b>MAIN BOX (Combiner Box)</b> and all accessories necessary for proper working approved by the engineer in charge. As specified in the drawings. Warranty 10 years	U	78	USD			ISO 9001/2015, 14001 Certified; IEC Certified
2	Supply and install steel structure to support the PV panels ,with all the required accessories to fix and direct the panels including aluminium rails, mid clamps , end clamps and all necessary accessories for fixation . Galvanized steel thickness 2.5 mm designed to withstand up to 145 KM PER HOUR wind speed. Steel structure shall be fabricated as per the drawings, but in case of any change on the structure due to the size of the contractor selected panels or due to site conditions, the contractor shall take this change into account in his price offer. Anti-rust treatment and epoxy painting shall be done at welding areas. All welding shall be done by experienced welders to the highest standards of workmanship and to the satisfaction of the Engineer. Contractor shall by all means be responsible for the installation, safety and quality of the steel structure so it withstands all applied loads and conserve the safety of the existing structures	U	9	USD			Steel Structure for 6 Panels as per the attached drawings

3	Supply and install steel structure to support the PV panels ,with all the required accessories to fix and direct the panels including aluminium rails,mid clamps , end clamps and all necessary accessories for fixation . Galvanized steel thickness 2.5 mm designed to withstand up to 145 KM PER HOUR wind speed . Steel structure shall be fabricated as per the drawings, but in case of any change on the structure due to the size of the contractor selected panels or due to site conditions, the contractor shall take this change into account in his price offer. Anti-rust treatment and epoxy painting shall be done at welding areas. All welding shall be done by experienced welders to the highest standards of workmanship and to the satisfaction of the Engineer. Contractor shall by all means be responsible for the installation, safety and quality of the steel structure so it withstands all applied loads and conserve the safety of the existing structures	U	3	USD			Steel Structure for 8 Panels as per the attached drawings
4	SUPPLY AND INSTALL POWER INVERTER, TO PRODUCE APPROXIMATLY 3500 Watt. <b>Technical Detail:</b> 3500 watt inverter ,Off Grid type , solar charger MPPT ,Hybrid GRADE A (GROWATT , FELECITY OR EQUIVALENT ). Rated Power : 3500VA/3500W.DC Input : 24VDC , 162A;AC Output : 230VAC 50/60HZ - Warranty 5 years	U	9	USD			ISO 9001/2015 Certified; IEC Certified
5	Supply and install Power inverter ,to produce approximatly 5000 watt. <b>Technical Details :</b> 5000 watt inverter ,Off Grid type ,solar charger MPPT ,Hybrid GRADE A (GROWATT -FELECITY OR EQUIVALENT).Rated Power: 5000VA/5000W;DC Input: 48VDC , 135A;AC Output: 230VAC 50HZ - Warranty 5 years	U	3	USD			ISO 9001/2015 Certified; IEC Certified
6	SUPPLY AND INSTALL HIGH QUALITY Tall Tubular BATTERIES DEEPCYCLE 12V 200 AH C10 2500 LIFE CYCLE AT 50% D.O.D-- MINIMUME LIFE WORKING TIME 5 YEARS	U	30	USD			
7	Supply and install heavy duty plastic cash cable for 2* 6 mm2 cables	L.m	520	USD			
8	Supply and install heavy duty plastic cash cable for 2* 10 mm2 cables	L.m	95	USD			
9	Supply and install heavy duty plastic cash cable for 2*35 mm2 cables	L.m	39	USD			
10	Supply and Install an electrical Copper cable 1Cx2.5 mm2 with all fittings , connections & cash cable -National Brand or equivalentnt	L.m	485	USD			
11	Supply and Install an electrical Copper cable 1Cx4 mm2 with all fittings , connections & cash cable - National Brand or equivalentnt	L.m	110	USD			
12	Supply and install an electrical PVC DC cable 6 mm2 ,cabling and accessories , heat resistance cable , battery and inverter -Improved fire resistant performance; Rated Voltage 1000V -- National Brand or equivalent .	L.m	520	USD			IEC Certified
13	Supply and install an electrical PVC DC cable 10 mm2 ,cabling and accessories , heat resistance cable , battery and inverter,Improved fire resistant performance; Rated Voltage 1000V -National Brand or equivalent .	L.m	95	USD			IEC Certified
14	Supply and install an electrical PVC DC cable 35 mm2 ,cabling and accessories , heat resistance cable , battery and inverter,Improved fire resistant performance; Rated Voltage 1000V -National Brand or equivalent .	L.m	39	USD			IEC Certified
15	Supply and installed the AC circuit breaker of (10A) inside the panel board, - IEC 60947-2 - CE marked - Europeand Brand or equivalent	U	9	USD			
16	Supply and install 2P AC circuit breaker of (16A) inside the panel board. - IEC 60947-2 - CE marked - Europeand Brand or equivalent	U	3	USD			
17	Supply and instal 2P DC circuit breaker of (100A) inside the panel board. - IEC 60947-2 - CE marked - Europeand Brand or equivalent	U	12	USD			

18	Supply and install 2P DC circuit breaker of (20A-500V) inside the panel board. - IEC 60947-2 - CE marked - European Brand or equivalent	U	12	USD			
19	Supply and install SPD 500V-20KA ;Operating Frequency 50/60Hz; Response time 25ns;European Brand or equivalent	U	24	USD			
20	Supply and install fuse pair 20A- 500V	U	12	USD			
21	Fixation of the footing of the Galvanized steel structure using curbstone( 50*15*30) cm with concrete coating (50*15*30 )cm . As specified in the drawing .	U	624	USD			
22	Supply and Install wall-mounted Plastic electrical panel board water proof IP65 including the port fuse ,fuses , voltage protector and surge arrester with all necessary junction 16 way	U	12	USD			
23	Supply and install 30W LED lamps- Grade A-Best Quality	U	24	USD			
24	Supply and install wiring accessories ( Single Phase Switches, Sockets ) with cover as requested by the engineer -Best Quality	U	13	USD			To be installed based on the request of the engineer
25	Supply and install of Plywood sheet (122*244) with thickness 6mm with all accessories	U	4	USD			
26	Supply and install of timber 4m *0.8*0.8 cm with all accessories and fixation	U	4	USD			
27	Cutting and removing the Asphalt road outside the site using machine with dimensions (width =20 and depth = 30) cm .	L.m	22	USD			
28	Cast in-situ reinforced concrete including double iron mesh (T12:15 cm)	M3	1.32	USD			
29	Supply and install UPVC pipe for underground usage-25mm	l.m	22	USD			
30	Supply and install 30W LED lamps- Grade A-	U	31	USD			
31	Supply and install switches & socket with cover and all accessories	U	27	USD			
32	Supply and install fire extinguisher-2kg-Powder type-Powder concentration 82%- Discharge time <15 seconds-	U	12	USD			
33	Supply and install stainless steel plates 20cm*20cm for visibility - Design will be given by LebRelief.	U	12	USD			

Sales tax (if applicable)	ضريبة المبيعات (إن وجدت)
Delivery charge (if applicable)	قيمة الشحن (إن وجدت)
Other charges (if applicable)	تكاليف أخرى (إن وجدت)
<b>TOTAL</b>	<b>المجموع الكامل</b>

<b>Additional information required from supplier:</b> معلومات أخرى مطلوبة من المزود	
<b>[1] Quote validity period</b> مدة صلاحية عرض السعر	Minimum 6, ideally 9 months.
<b>Other عروض أخرى</b>	<ul style="list-style-type: none"> <li>الكميات اعلاه قابلة للزيادة او النقصان حسب الحاجة.</li> <li>الاسعار المعروضة من قبل المتعهد تظل ثابتة اذا حصل اي تغير في الكميات.</li> <li>يجب ان تتوافق النوعية و الجودة مع المواصفات المرفقة.</li> <li>سيتم أداء الدفعات وفقاً للكشف التقني المقدم من قبل المتعهد والموافق عليها من المهندس المسؤول عن المشروع في الجمعية.</li> </ul>

<b>Supplier confirmation of offer</b> تأكيد المتعهد عرض السعر	<b>Contractor signature</b> امضاء المتعهد	<b>Contact stamp</b> ختم المتعهد
Name الإسم :		
Job title الوظيفة :		
Date التاريخ :		



**Data sheet required for the materials below:**

1	PV Panels
2	Aluminium Rails and Clamps
3	Inverter 3.5kw
4	Inverter 5kw
5	DC Cables 6mm <sup>2</sup>
6	DC Cables 10mm <sup>2</sup>
7	DC Cables 35mm <sup>2</sup>
8	Circuit breakers 10A
9	Circuit breakers 16A
10	DC Circuit Breaker 100A
11	DC Circuit Breaker 20A
12	SPD 500V
13	Fuse 20A
14	Wall mounted Plastic panel board
15	Wiring accessories
16	LED Lamp
17	UPVC Pipe
18	Fire Extinguisher

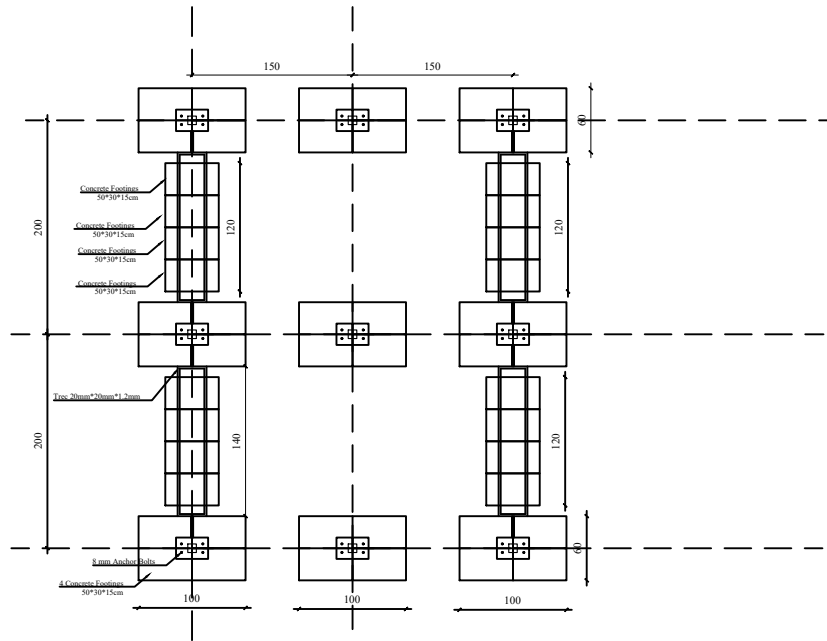

CONCRETE PLAN

SHOP DRAWING

SOUTH DIRECTION

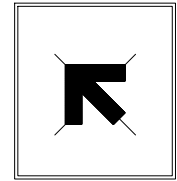

Legend :

Plan :

CONCRETE PLAN

Drawing Title :

6 Panels Solar System

1 of 1

Lebanese Relief Council





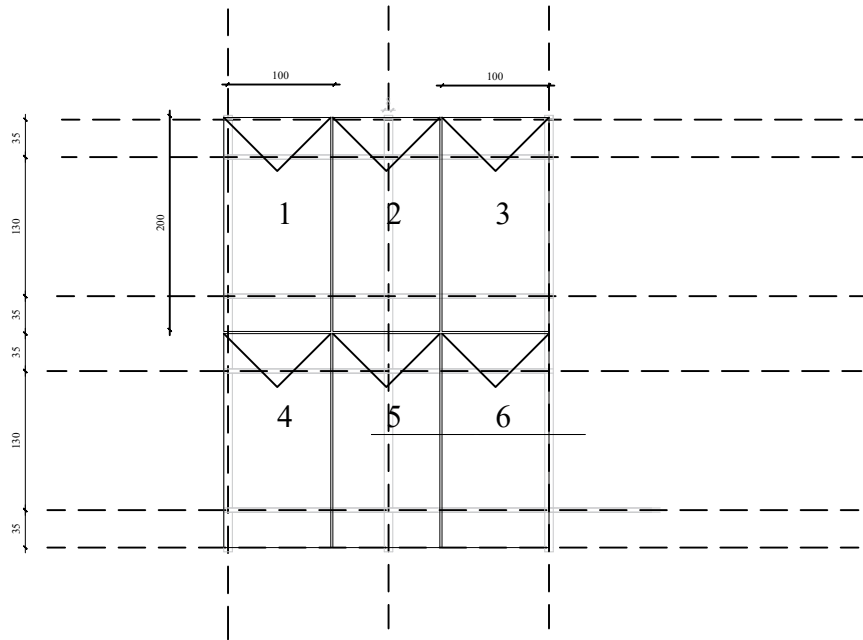

PV LAYOUT

SHOP DRAWING

SOUTH DIRECTION

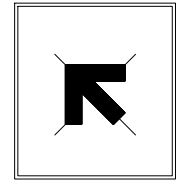

Legend :

Plan :

PV LAYOUT

Drawing Title :

6 Panels Solar System

1 of 1

Lebanese Relief Council

\\.\Pictures\logo LebRelief.png

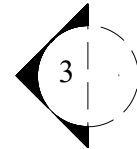
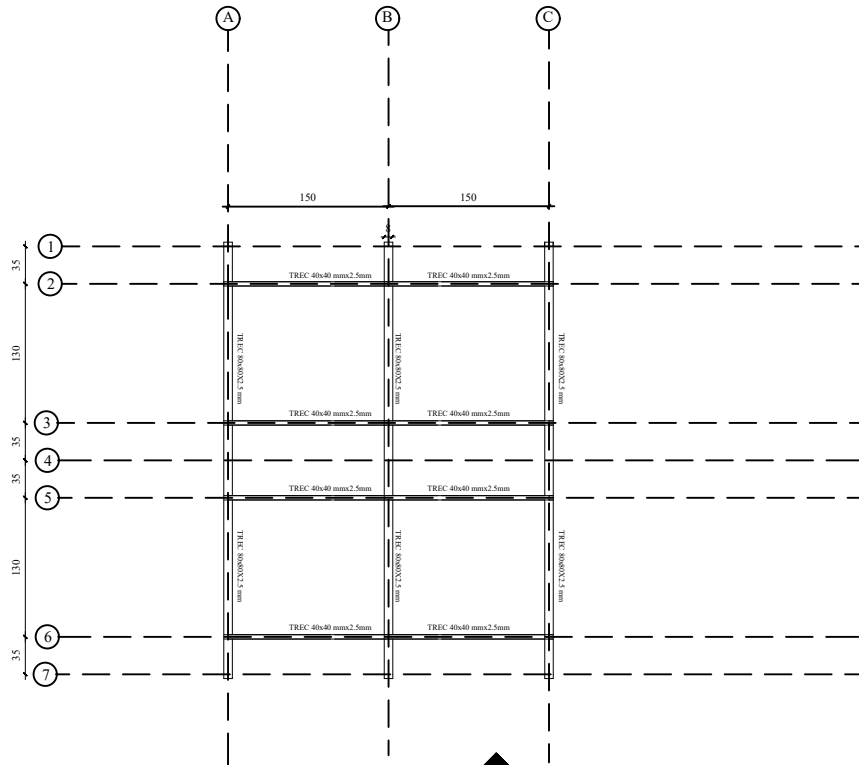

STRUCTURAL PLAN

SHOP DRAWING

SOUTH DIRECTION

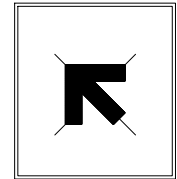

Legend :

Plan :

GENERAL PLAN

Drawing Title :

6 Panels Solar System

1 of 1

Lebanese Relief Council



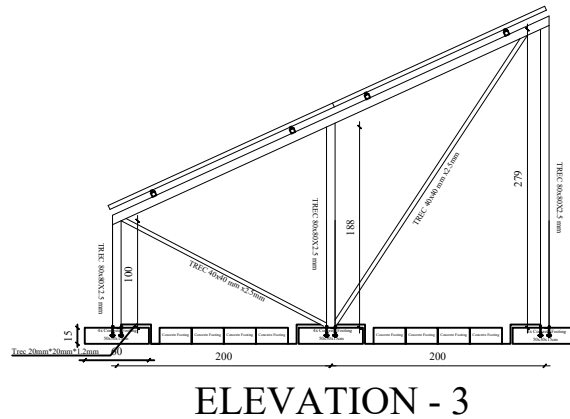
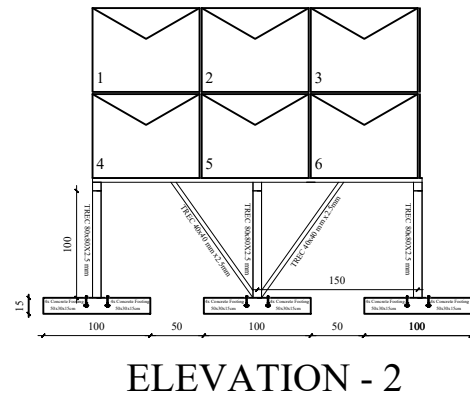
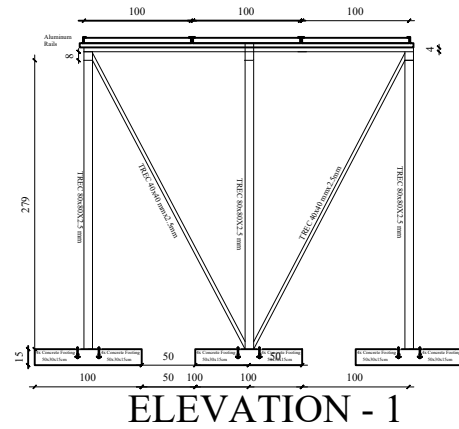

SHOP DRAWING

SOUTH DIRECTION

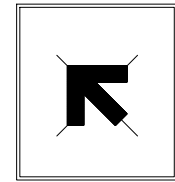

Legend :

Plan :

GENERAL PLAN

Drawing Title :

6 Panels Solar System

1 of 1

Lebanese Relief Council



# SHOP DRAWING

SOUTH DIRECTION

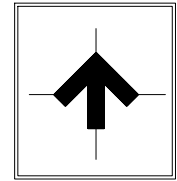

Legend :

Plan :

SLD

Drawing Title :

6 Panels Solar System

1 of 1

Lebanese Relief Council

..\\..\\Pictures\\logo LebRelief.png

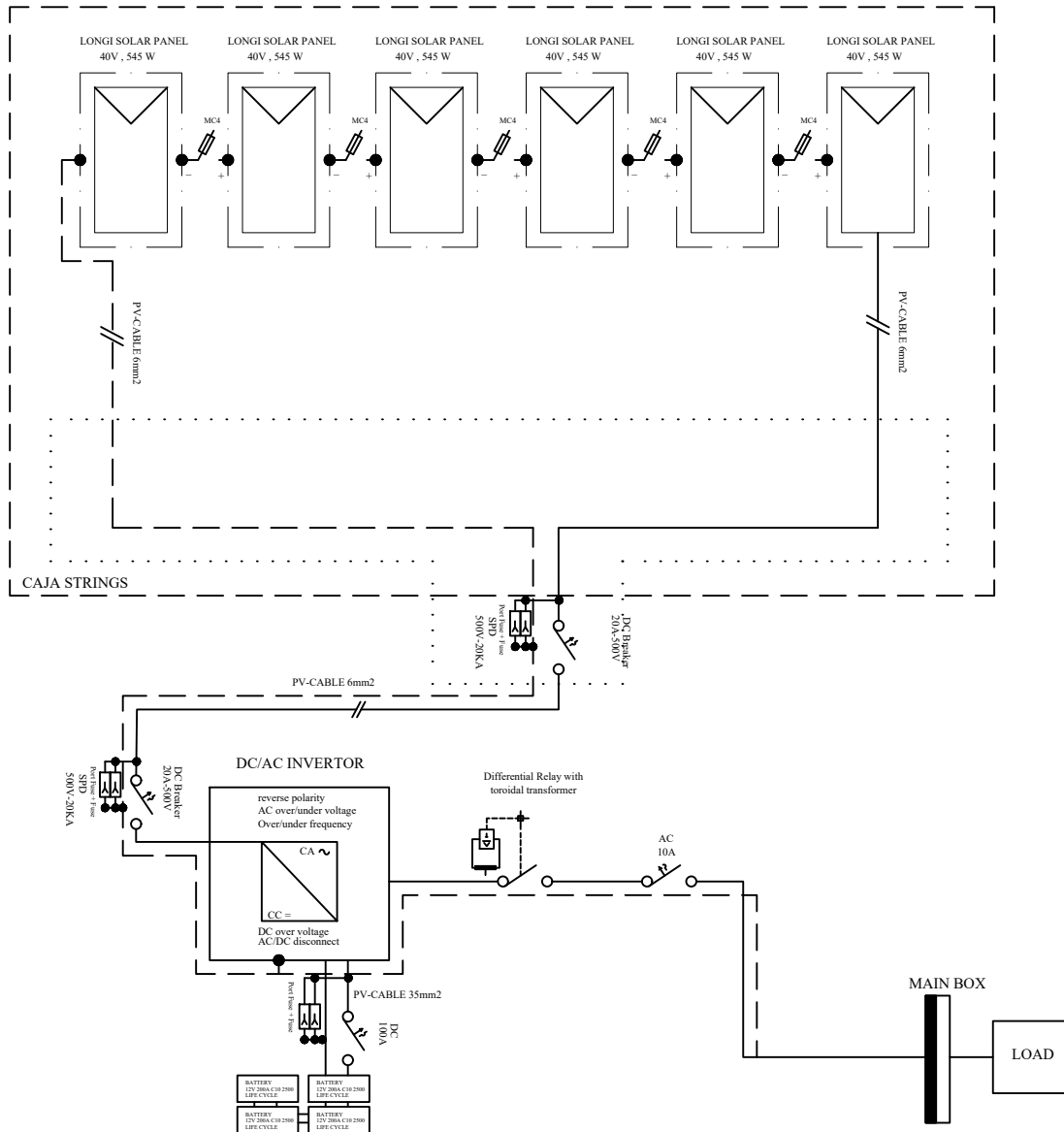



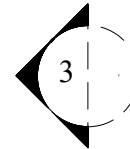
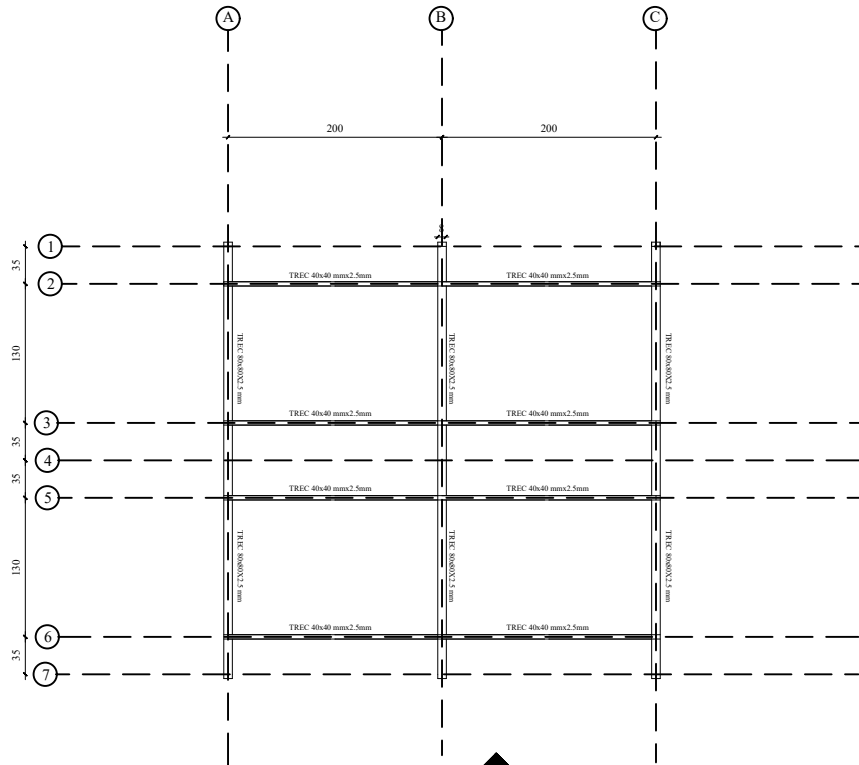

STRUCTURAL PLAN

SHOP DRAWING

SOUTH DIRECTION

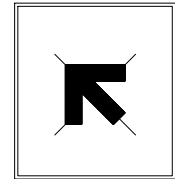

Legend :

Plan :

GENERAL PLAN

Drawing Title :

8 Panels Solar System

1 of 1

Lebanese Relief Council



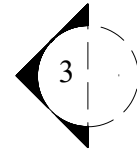
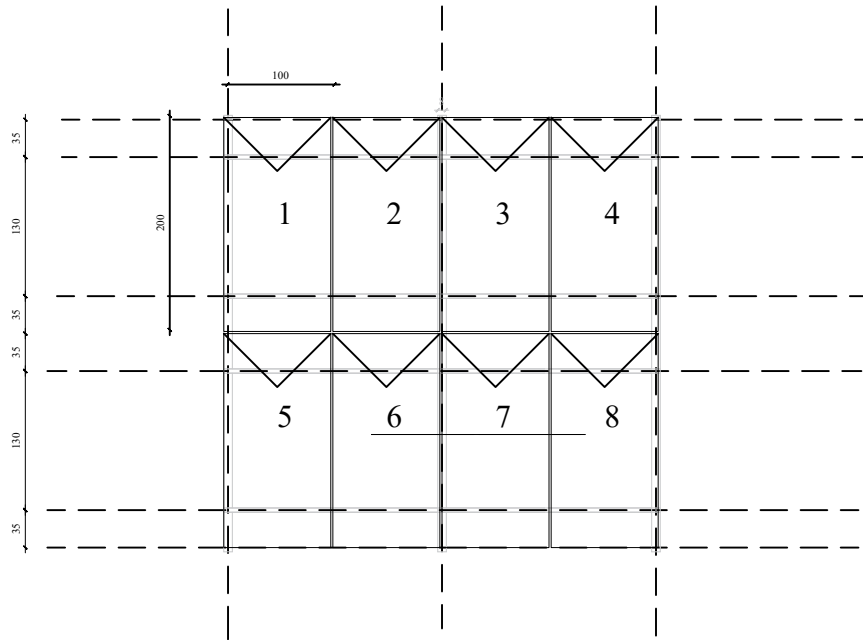

# PV LAYOUT

## SHOP DRAWING

SOUTH DIRECTION

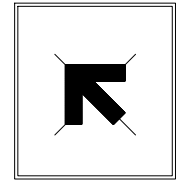

Legend :

Plan :

GENERAL PLAN

Drawing Title :

8 Panels Solar System

1 of 1

Lebanese Relief Council



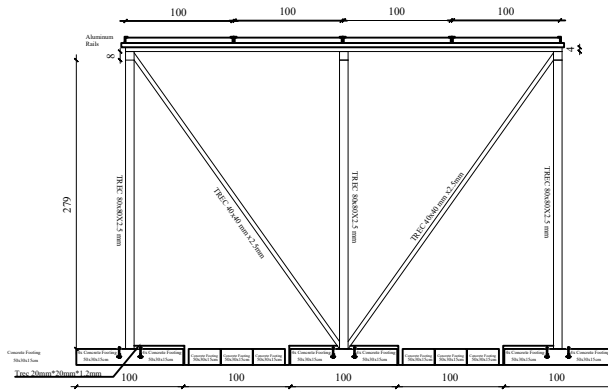

ELEVATION - 1

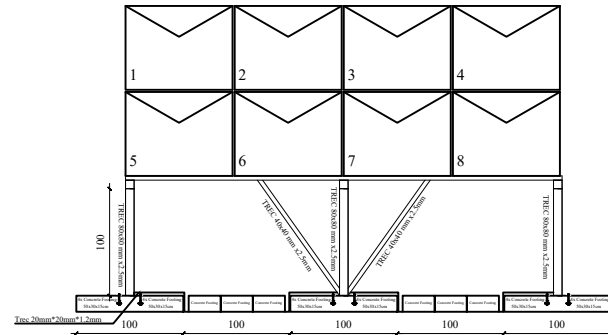

ELEVATION - 2

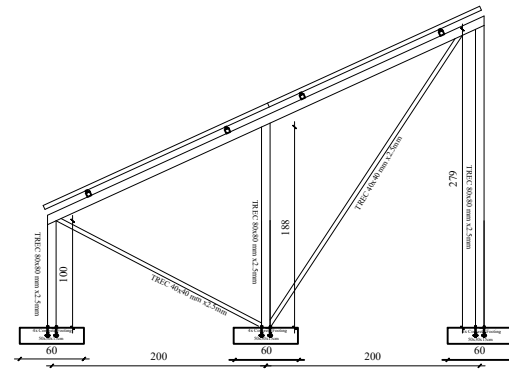

ELEVATION - 3

SHOP DRAWING

SOUTH DIRECTION

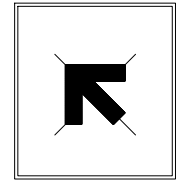

Legend :

Plan :

GENERAL PLAN

Drawing Title :

8 Panels Solar System

1 of 1

Lebanese Relief Council





# SHOP DRAWING

SOUTH DIRECTION

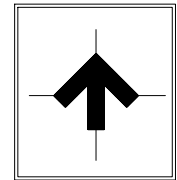

Legend :

Plan :

ELECTRICAL SLD

Drawing Title :

8 Panels Solar System

1 of 1

Lebanese Relief Council

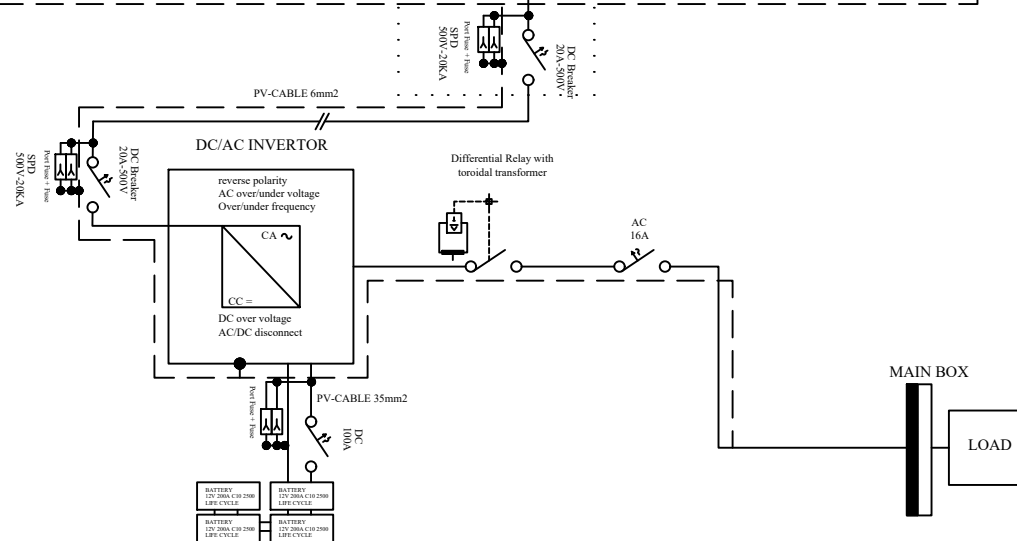
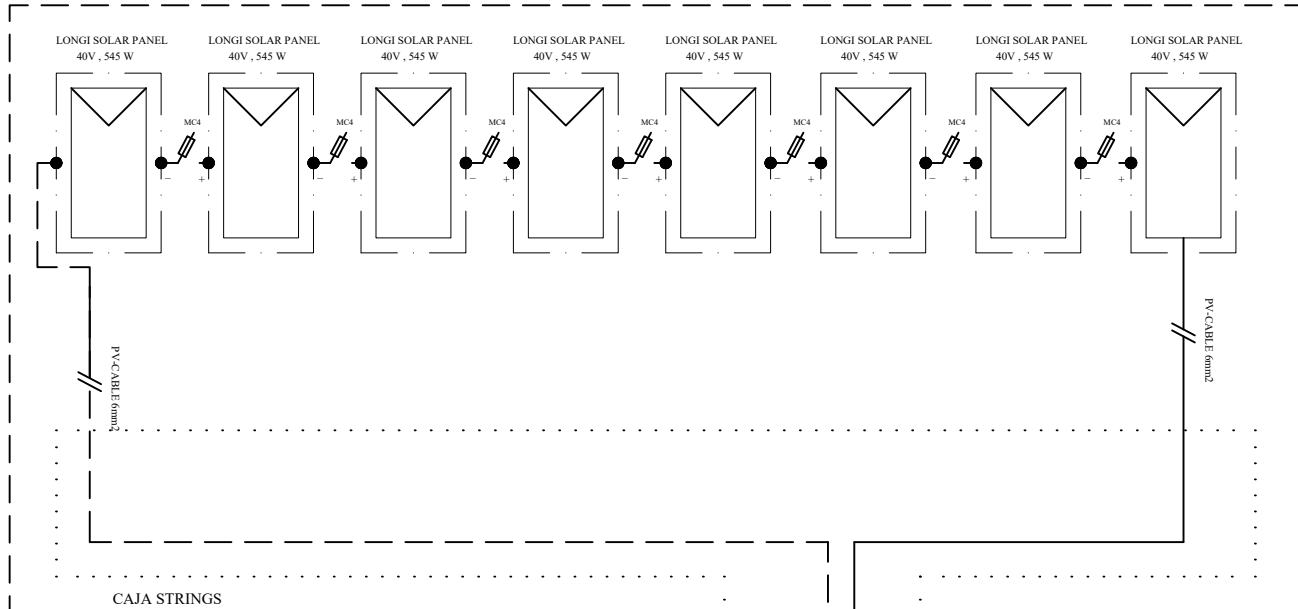

## SWORN DECLARATION BY TENDERERS INVOLVED IN THE IMPLEMENTATION OF A GRANT FINANCED BY EXPERTISE FRANCE

To be attached to the [application/tender/contract]<sup>1</sup>

---

Object of the service/supply/works purchase contract: Works

In the context of the Grant contract covering: Installation of PV solar system in Tripoli

---

1. We acknowledge and accept that, in the aforementioned circumstances, Expertise France shall be entitled to exclude our company from the tender procedure for services/supplies/works in the context of the implementation of a Grant financed by Expertise France and, should the contract be awarded to our company, any such situation may lead to termination of the contract, in accordance with the terms of the latter.
  
2. We hereby declare that neither we, nor any member of our consortium, nor any supplier, service provider, consultant or subcontractor (including the directors, employees and agents of said entities) nor any person holding the power of representation, decision-making or control over said persons, is in any of the following situations:
  - a) Bankruptcy or proceedings relating to bankruptcy, liquidation, safeguarding or cessation of operations, or any similar situation resulting from proceedings of the same nature;
  
  - b) Or has been the subject of:
    - i. A ruling dated from within the past five years with the force of res judicata in the country of implementation of the contract for fraud, corruption or any offence committed in the context of an award or performance of a tender or contract; in the event of any such ruling, we reserve the right to append additional information to this Integrity Undertaking specifying that said ruling is not relevant to the contract;
  
    - ii. An administrative sanction dated from within the past five years by the European Union or by the competent authorities of the country in which we are established for fraud, corruption or any offence committed in the context of an award or performance of a tender or contract; in the event of any such sanction, we reserve the right to append additional information to this Integrity Undertaking specifying that said sanction is not relevant to the contract;
  
    - iii. A ruling dated from within the past five years with the force of res judicata for fraud, corruption or any offence committed in the context of an award or performance of a contract financed by the AFD;

Supported by

Avec la  
participation  
de

Implemented by

- c) Feature on any sanctions list adopted by the United Nations, European Union or France, notably in respect of anti-money laundering, counter-financing of terrorism and the undermining of international peace and security.
- d) Any termination issued solely due to failings on our part within the past five years as a result of us having committed any serious or persistent breach of our contractual obligations during the performance of a previous tender or contract, subject to said sanction not currently being contested by us or which has led to a court ruling dismissing said termination solely due to failings on our part;
- e) Any breach of our obligations to pay taxes in accordance with the legal provisions of the country in which we are established or those of the country of the contracting authority;
- f) Any exclusion decision issued by the World Bank or to feature in this regard on the list published at <http://www.worldbank.org/debar>; in the event of any such exclusion decision, we reserve the right to append additional information to this Integrity Undertaking specifying that said exclusion decision is not relevant to the contract;
- g) Or has produced false documents or been found guilty of false declarations when providing documents demanded by the contracting authority in the context of this contract award process.

3. We hereby declare that neither we nor any member of our consortium or our suppliers, contractors, consultants or service providers is confronted by any of the following conflicts of interest:

- a) Being a shareholder controlling the contracting authority or a subsidiary controlled by the contracting authority, unless the resultant conflict has been notified to Expertise France and been resolved to its satisfaction;
- b) Having a business or family relationship with any member of the contracting authority's departments who is involved in the contract award or supervision process, unless the resultant conflict has been notified to Expertise France and been resolved to its satisfaction;
- c) Controlling or being controlled by another bidder or consultant, being under the control of the same company as another bidder or consultant, receiving from another bidder or consultant or awarding a grant to another bidder or consultant, whether directly or indirectly, having the same legal representative as another bidder or consultant, directly or indirectly maintaining contacts with another bidder or consultant enabling us to have access and provide access to information contained in our respective bids or proposals, or of influencing such bids or proposals or the decisions of the bidder or consultant;
- d) Having been engaged to provide intellectual services, the nature of which runs the risk of being incompatible with our assignments carried out on behalf of the bidder or consultant.
- e) In the case of a procedure covering the award of a works, supplies or equipment contract:
  - i. We have ourselves prepared or have been supported by a consultant who has prepared the specifications, plans, calculations and other documents used in the context of the contract award procedure.

- ii. We have ourselves, or one of the firms with which we are affiliated, been recruited, or will be recruited, by the contracting authority to supervise or audit the works under the contract.
4. If we are a public institution or public company, to be able to participate in a competitive tender we hereby certify that we enjoy legal and financial autonomy and that we are governed by the rules of company law.
5. We undertake to notify the contracting authority without undue delay, which will in turn notify Expertise France, of any change of situation with regard to points 2 to 4 above.
6. In the context of contract award and execution:
  - a) We have not committed and will not commit any unfair practices (action or omission) designed, with regard to any third party, to deliberately deceive, intentionally conceal information, inveigle or vitiate consent, circumvent legislative or regulatory obligations or violate internal rules in order to obtain an illegitimate benefit.
  - b) We have not committed and will not commit any unfair practices (action or omission) contrary to our legislative or regulatory obligations and/or internal rules in order to obtain an illegitimate benefit.
  - c) We have not promised, offered or granted, nor will do so in the future, whether directly or indirectly, to (i) any person holding a legislative, executive, administrative or judicial office within the country of the contracting authority, whether such person is appointed or elected, permanently or otherwise, remunerated or otherwise and regardless of their hierarchical level, (ii) any other person exercising a public function, including for a public body or public company, or which provides a public service, or (iii) any other person defined as a public official in the country of the contracting authority, any undue advantage of any kind, to the person directly or for any other person or entity, to incite said person to take action or omit to take action during the exercise of their official public functions.
  - d) We have not promised, offered or granted, nor will do so in the future, whether directly or indirectly, to any person managing a private-sector entity or working for any such entity in any capacity whatsoever, any undue benefit of any kind, to the person directly or for any other person or entity, to incite said person to take action or omit to take action in breach of their legal, contractual or professional obligations.
  - e) We have not committed, nor will do so in the future, any act likely to influence the contract award process to the detriment of the contracting authority, notably no anti- competitive practices having the purpose and effect of preventing, restricting or distorting fair competition, notably by limiting access to the contract or the free exercise of competition by other companies.
  - f) We hereby certify that neither we ourselves nor any member of our consortium or any of our subcontractors will acquire or supply goods or take action in sectors subject to embargo implemented by the United Nations, the European Union or France.

- g) We undertake to comply with, and shall obtain a similar undertaking from all our subcontractors, the environmental and social standards recognised by the international community, including the fundamental conventions of the International Labour Organisation (ILO), conventions of freedom of association and collective bargaining, on the elimination of forced labour, on the elimination of discrimination in employment, on the elimination of child labour and international agreements on environmental protection, in compliance with the laws and regulations applicable in the country of contract implementation. Furthermore, we undertake to implement mitigation measures against environmental and social risk where stated in the environmental and social management plan provided by the contracting authority.

We acknowledge and accept that, should any of the aforementioned situations be identified to apply to us, the Beneficiary of the Grant would be obliged to forward such information to Expertise France, or to the Donor of the financing or any other entity of the Agence Française de Développement group, and that said parties may integrate such information within a rapid detection and exclusion system, including publication on their website.

With regard to this declaration, we undertake to notify Expertise France without delay of any change to our situation during the tender process and, as applicable, during contract execution.

Name: \_\_\_\_\_ Function: \_\_\_\_\_

Duly authorised to sign on behalf of:<sup>1</sup> \_\_\_\_\_

Date: \_\_\_\_\_

Signature: